

XMZ 6000 INTELLIGENT DIGITAL INDICATOR

OPERATING INSTRUCTION

1.	Functions and features.....	1
2.	Ordering number.....	2
3.	Input signal type.....	3
4.	Trouble shooting.....	6
5.	Installation wiring.	8
6.	Panel display.....	10
7.	Operation diagram.....	11
8.	Parameter setting diagram. . .	12

1. Application and feature

1. Application

XMZ6000 is suitable for the temperature pressure lever and flow measurement and display in variant industry process.

2. Feature

- Designed based on computer processor, it can be programmed by keys on the panel to suit any type of sensor, and there is no linear error for any sensor.
- Auto-zero calibration, there is no temperature drift and time drift, no need to calibrate again even two years later.
- All parameters are stored in an EEPROM which is safe for all case and for long time.
- With RS232 or RS485 communication port, it may communicate with computer or DCS system.

3. Technique parameter

- Environment condition: temperature: 0 ~ 50°C , relation humidity: ≤90%
- Power supply: AC90V ~ 265V (50 ~ 60HZ) or DC24±10%V
- Accuracy : 0.5%F.S±1digital, dissolution: 0.001,0.01,0.1,1
- Input feature: TC: input impedance >10MΩ, RTD: wire resistance 0~5Ω, three wires are the same
Voltage input: input impedance >300kΩ, mA: input impedance 250Ω
- Inside cold terminal compensation temperature: 0 ~ 50°C
- Power dissipation: <3W Weight<0.5kg

2. Ordering number

Ordering number		Explain
XMZ		Intelligent digital indicator
Series	5	Electronic transformer
	6	Linearity transformer
Control type	0	No alarm
Type of input	1	For thermocouple
	2	For resistance
	3	For mV signal sensor
	4	For 30~350 Ω sensor
	5	For 0~10mA
	6	For 4~20mA
	7	For 0~5V
	8	For 1~5V
	9	For special sensor
	U	Any sensor
Output	0	No transfer output
Outline	V	160×80×80mm horizontal type
	F	80×160×80mm vertical type
	S	96×96×110mm square type
	SV	96×48×110mm horizontal type (only to XMZ5000)
		48×96×110mm vertical type (only to XMZ5000)
Power output		Without transmitter power output
	P	With 24V transmitter power output
Power supply		Power supply 220VAC
	D	Power supply 24VDC (no to S, SV outline)
Communication port		Without communication port
	-RS232	With RS232 isolated port
	-RS485	With RS485 isolated port

3. Input signal type

3.1. Linear input and measurement range

Input type	Display symbol	Resolution	Measurement range	Suitable sensor	Reference to 3.4
Standard linear input	Linearity	10μA	-1999~9999	0-10mA input	
	Linearity	10μA	-1999~9999	4-20mA input	
	Linearity	1mV	-1999~9999	0-5V input	
	Linearity	1mV	-1999~9999	1-5V input	
Un-standard linear input		1mV	-1999~9999	Un-standard linear input (>60mV)	
Standard linear input	Extract	10μA	-1999~9999	0-10mA input	
	Extract	10μA	-1999~9999	4-20mA input	
	Extract	1mV	-1999~9999	0-5V input	
	Extract	1mV	-1999~9999	1-5V input	
Un-standard square root input		1mV	-1999~9999	Un-standard square root input (>60mV)	

3.2. RTD input and measurement range

Input type	Display symbol	Resolution	Measurement range	Suitable sensor	Reference to 3.4
Pt100		1°C	-200~600°C	Platinum R0=100Ω	
Pt100.0		0.1°C	-199.9~200.0°C	Platinum R0=100.0Ω	
Pt10		1°C	-200~850°C	Platinum R0=10Ω	
Cu100		0.1°C	-50.0~150.0°C	Copper R0=100Ω	
Cu50		0.1°C	-50.0~150.0°C	Copper R0=50Ω	
30~350Ω		0.1Ω	User setting	Pressure gauge 30-350Ω	

3.3. TC input and measurement range

Input type	Display symbol	Resolution	Measurement range	Suitable sensor	Reference to 3.4
B		1°C	700~1800°C	TC type: B	
R		1°C	0~1760°C	TC type: R	
S		1°C	0~1600°C	TC type: S	
N		1°C	0~1400°C	TC type: N	
K		1°C	0~1300°C	TC type: K	
E		1°C	0~800°C	TC type: E	
J		1°C	0~600°C	TC type: J	
T		1°C	-200~400°C	TC type: T	
Un-standard mV signal		0.01 mV	-1999 ~ 9999	Any input within 0~ 60mV	

3.4. DIP switch sketch map

3.4.1. 96×96 square type sketch map

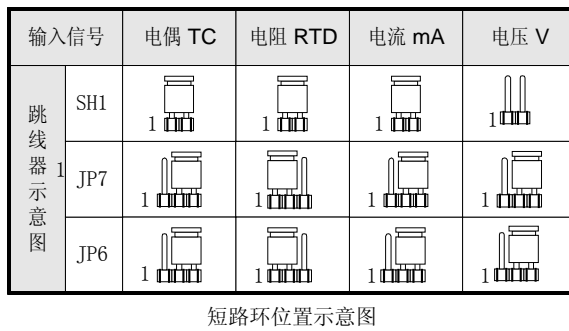
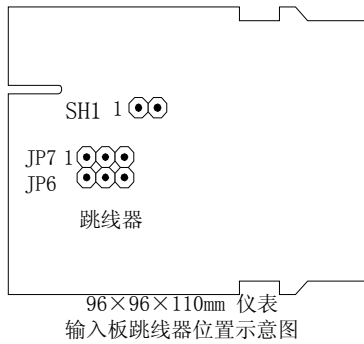

3.4.2 160×80 horizontal type and 80×160 vertical type sketch map

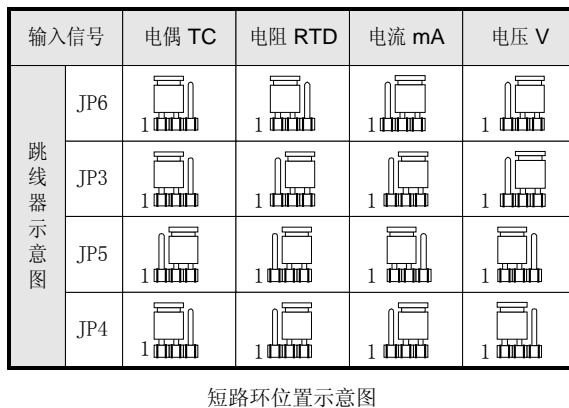
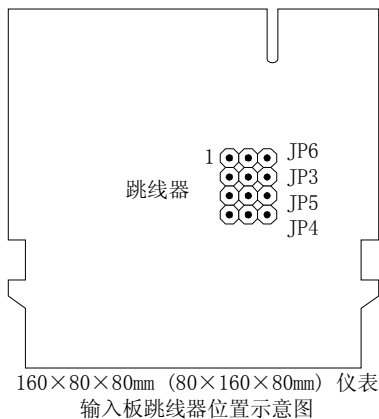

4. rouble shooting

4. 1. Trouble shooting

Trouble		Cause	Eliminate method
Not lighting		Power fail	Check the power
		Power terminal fail	Take out the device core and check the power terminal
		Device go wrong	Contact to the distribute or manufacture
LED display		Input type setting wrong	Check the input type setting
		Input signal overflow	Check the input signal
		Input signal line break	Check the input signal wire
		Input type wrong	Check the input type setting
		Input signal overflow	Check input signal
		Calibration wrong	Calibration the input again
		Input type wrong	Check input type setting
		Input signal under -range	Check input signal
Calibration wrong		Calibration the input again	
Display wrong		Input type wrong	Check the input type setting
		Correction menu setting wrong	Check the correction setting menu
Trouble		Cause	Eliminate method
Display wrong		Input wire wrong	Check the input wire
		Input signal wrong	Check the input signal
Can not enter the corresponding menu		Device type wrong	Contact to the distribute or manufacture
		The menu be locked	Unlock the menu
Can't unlock the menu		Lose the unlock code	Contact to the distribute or manufacture
Display change suddenly		Influenced by the rear contactor's spark	Ac circuit, join a resistor-capacity spark-absorbent.
			DC circuit join a reverse diode
		Wrong wiring	Separate signal wire from power wire
		Disturbance of the power	Shield the signal wire and connect the shield to the ground on panel end.
The power board burned out		Wrong connection of the power line	Check the connection of the power line
		Bad power quality	Add purifying power, connect to other power
Relay action wrong		Influenced by the rear contactor's spark	Ac circuit, join a resistor-capacity spark absorbent. DC circuit, join a reverse diode

5. Installation and wiring

5. 1. Note: Signal cable should depart from the power supply, and must be the shield cable, and the shield must be connected to the signal earth, to avoid the signal influence

5. 1. 2. The device power should be an independent power, a cleaning power, and should not be connected to other polluted power.

5. 2. XMZ6000 (160×80×80mm, 80×160×80mm) series wiring

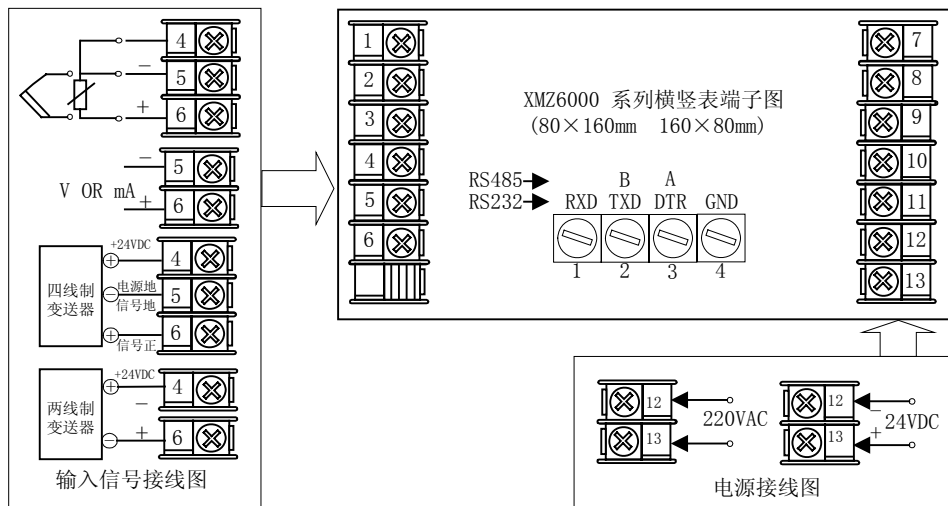

Note:1. Modem and PRN's wiring are the same as RS232's wiring

2. We keep the right to promote the products, if there are difference between operation instruction and case back wiring, the case back wiring is always the right.

5.3. XMZ5000 (96×96×110mm) series wiring

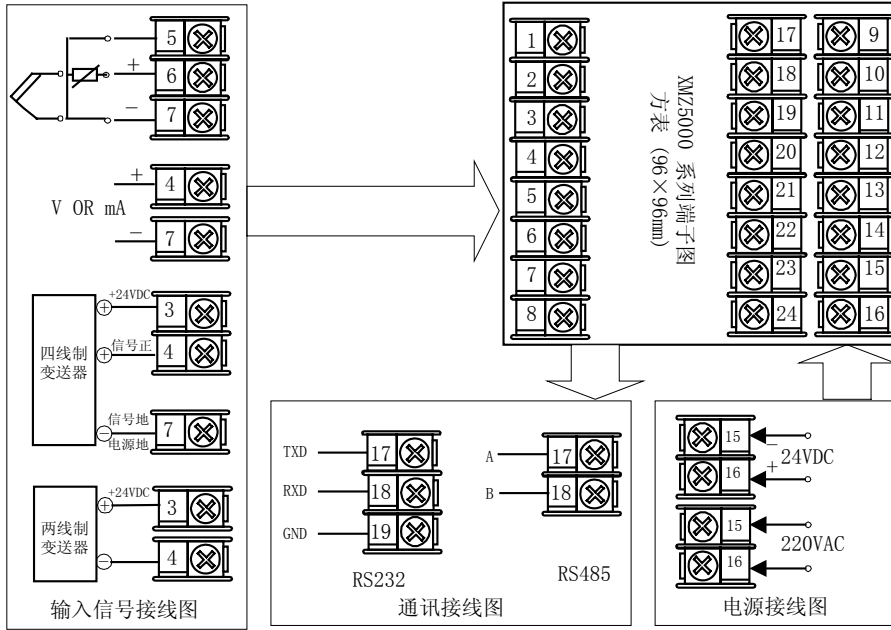

Note:1. Modem and PRN's wiring are the same as RS232's wiring

2. We keep the right to promote the products, if there are difference between operation instruction and case back wiring, the case back wiring is always the right.

6. Panel display

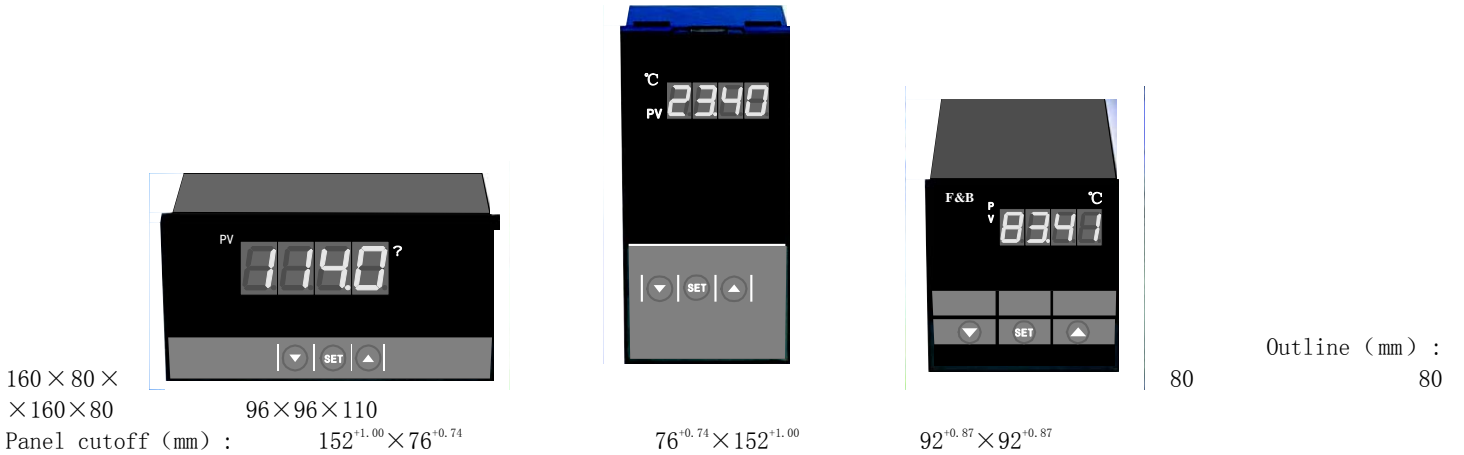

Name		Content
Display		<ul style="list-style-type: none"> When in working state, it indicates input. When in setting state, it indicates parameter name or parameter value.
KEY	▽	It is used to decrease parameter in setting state.
	SET	It is used to confirm parameter setting in setting state.
	△	It is used to increase parameter in setting state.

7. Operation diagram

- Note: ① Keeping no key operate 40 seconds in setting state, it will return to working state automatically; ② If some menu can not be seen, it may be locked or have not the function
- The symbol ▽, S, △ in the drawing means pressing the key ▽, SET, △, the content in the pane is display message in upper and lower display.

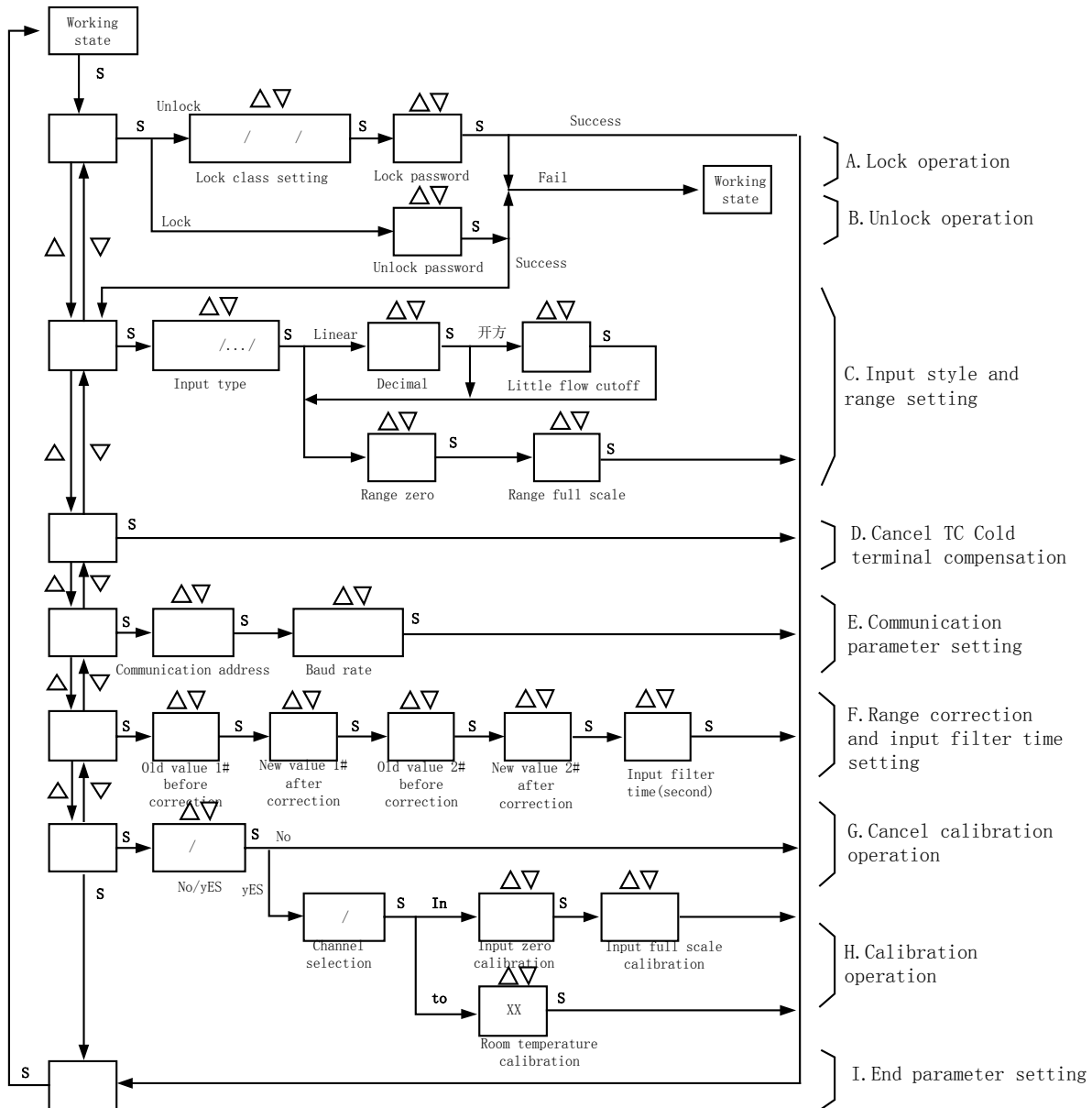





8. Parameter setting operation

A. Lock operation

B. Unlock operation

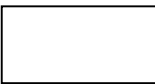
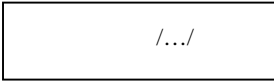
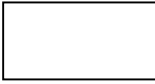
Menu and operation	Factory setting	Parameter explain
<div style="border: 1px solid black; width: 40px; height: 20px; display: inline-block;"></div> <ul style="list-style-type: none"> Entry of the lock and unlock menu group Press key SET to confirm Press key △、▽ to exit 		Entry of the lock and unlock menu group
A.		
<div style="border: 1px solid black; width: 60px; height: 20px; display: inline-block; text-align: center;">/ /</div> <ul style="list-style-type: none"> Lock class setting Press key △、▽ to change Press key SET to confirm 		: Lock all menu : Lock all menu except alarm menu : Lock calibration menu only
<div style="border: 1px solid black; width: 60px; height: 20px; display: inline-block;"></div> <ul style="list-style-type: none"> Lock password setting Press key △、▽ to modify Press key SET to confirm 		Lock password Note: "00" is a invalid password
B.		
<div style="border: 1px solid black; width: 60px; height: 20px; display: inline-block;"></div> <ul style="list-style-type: none"> Input unlock password Press key △、▽ to modify Press key SET to confirm 		Unlock password



C. Input signal type and range setting

Menu and operation		Factory setting	Explain
	<ul style="list-style-type: none"> ● Entry of the range menu group ● Press key SET to confirm ● Press key Δ、∇ to exit 		Entry of the range menu group
	<ul style="list-style-type: none"> ● Input signal type selection ● Press key Δ、∇ to modify ● Press key SET to confirm 	As ordering	Input signal type selection
	<ul style="list-style-type: none"> ● Input decimal position setting ● Press key Δ、∇ to modify ● Press key SET to confirm 	As ordering	Input decimal position setting
	<ul style="list-style-type: none"> ● Little flow cutoff setting ● Press key Δ、∇ to modify ● Press key SET to confirm 		Little flow cutoff setting (Engineering units)
	<ul style="list-style-type: none"> ● Range zero setting ● Press key Δ、∇ to modify ● Press key SET to confirm 	As ordering	Range zero setting
	<ul style="list-style-type: none"> ● Range full scale setting ● Press key Δ、∇ to modify ● Press key SET to confirm 	As ordering	Range full scale setting

D. Cancel TC cold terminal compensation

Menu and operation		Factory setting	Explain
	<ul style="list-style-type: none"> ● Cancel TC cold terminal compensation ● Press key SET to confirm ● Press key Δ、∇ to exit 		Turn on the power again, the TC cold terminal compensation will be recovered Compensation range:0~50℃

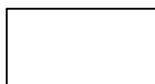
E. Communication parameter setting

Menu and operation		Factory setting	Explain
	<ul style="list-style-type: none"> ● Entry of the communication setting menu group ● Press key Δ、∇ to exit ● Press key SET to confirm 		Communication parameter
	<ul style="list-style-type: none"> ● Communication address setting ● Press key Δ、∇ to modify ● Press key SET to confirm 		Communication address: 01~254
	<ul style="list-style-type: none"> ● Communication baud rate setting ● Press key Δ、∇ to modify ● Press key SET to confirm 		:1200bps; :2400bps; :4800bps; :9600bps

F. Range correction and input filter time setting

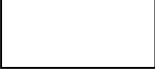
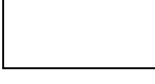
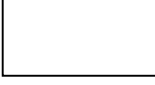
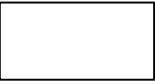
Menu and operation		Factory setting	Parameter explain
	<ul style="list-style-type: none"> ● Entry of error correction menu group ● Press key SET to confirm ● Press key Δ、∇ to exit 		Entry of error correction menu group
	<ul style="list-style-type: none"> ● The old display value 1# to be correct. ● Press key Δ、∇ to modify ● Press key SET to confirm 	00 or 0.0 or 0.00 or 0.000	The old display value 1# to be correct
	<ul style="list-style-type: none"> ● The new display value 1# after correct ● Press key Δ、∇ to modify ● Press key SET to confirm 	00 or 0.0 or 0.00 or 0.000	The new display value 1# after correct
	<ul style="list-style-type: none"> ● The old display value 2# to be correct. ● Press key Δ、∇ to modify ● Press key SET to confirm 	1000 or 100.0 or 10.00 or 1.000	The old display value 2# to be correct
	<ul style="list-style-type: none"> ● The new display value 2# after correct ● Press key Δ、∇ to modify ● Press key SET to confirm 	1000 or 100.0 or 10.00 or 1.000	The new display value 2# after correct

<ul style="list-style-type: none"> ● If the input sensor is a standard sensor, please do not change the factory setting of the correction menu. ● If there is display error exist, you can correct the error with correction menu, but need not to calibrate the device again. ● If the input signal is a special signal, you may regard it a standard input that its measurement range is 0-5000 first, then get the true measurement range with correction menu. And need not to calibrate the device with the true "zero" and full range signal. It is very convenient. ● Be caution: The correction value 1# and correction value 2# must be far away, and cannot be the same value, or else the device will go wrong. 			
	<ul style="list-style-type: none"> ● Filter time setting ● Press key Δ、∇ to modify ● Press key SET to confirm 		Filter time: -

G. Cancel calibration operation

H. Calibration operation

Menu and operation		Explain
	<ul style="list-style-type: none"> ● Entry of the calibration menu group ● Press key SET to confirm ● Press key Δ、∇ to exit 	Entry of the calibration menu group
G.		
	<ul style="list-style-type: none"> ● Exit the calibration operation ● Press key SET to confirm ● Press key Δ、∇ to exit 	Cancel calibration operation
H .		
/	<ul style="list-style-type: none"> ● Calibration channel selection ● Press key SET to confirm ● Press key Δ、∇ to exit 	Calibration channel selection :Input signal calibration :temperature calibration
	<ul style="list-style-type: none"> ● Input signal zero calibration ● Input a zero signal to the input terminal, keep steady for 10 seconds, press key SET to confirm ● 0~10mA/4~20mA zero signal is 0.000mA ● 0~5V/1~5V zero signal is 0.000V ● RTD zero signal is 100.00 Ω ● TC zero signal is 0.000mV 	Input signal zero calibration
	<ul style="list-style-type: none"> ● Input signal full scale calibration ● Input a full scale signal to the input terminal, keep steady for 10 seconds, press key SET to confirm ● 0~10mA/4~20mA full scale is 20.00mA ● 0~5V/1~5V full scale is 5.000V ● RTD full scale is 350.000 Ω ● TC full scale is 60.000mV 	Input signal full scale calibration
xxxx	<ul style="list-style-type: none"> ● Room temperature calibration ● Press key Δ、∇ to input room temperature ($^{\circ}\text{C}$) ● Press key SET to confirm 	Room temperature

I. End parameter setting

Menu and operation		Explain
	<ul style="list-style-type: none"> ● End parameter setting operation ● Press key SET to confirm ● Press key Δ、∇ to exit 	End parameter setting operation